

## Cylindrical fuse-link

Technical data	
Rated voltage	400 V a.c., 500 V a.c., 690 V a.c.
Rated current	CH 8 1-25 A/400 V
	CH 10 0,5-16 A/500 V, 20-32 A/400 V
	CH 14 2-25 A/690 V, 32-50 A/500 V
	CH 22 16-40 A/690 V (50 A/690 V aM), 50-100 A/500 V
Rated frequency	50 Hz
Rated breaking capacity	CH 8 50 kA
	CH 10 100 kA
	CH 14 2-25 A/80 kA, 32-50 A/120 kA
	CH 22 16-40 A/80 kA (50 A/80 kA aM), 50-100 A/120 kA
Characteristics	gG, aM
Body material	ceramic
Material of contact parts	CuZn28, gal.Ag

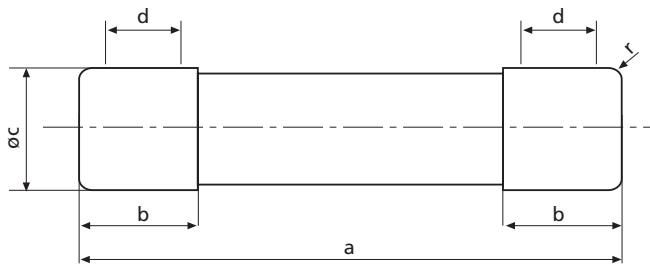

size	a	b <sub>max.</sub>	c	d <sub>min.*</sub>	r
8 x 32	31,5±0,5	6,7	8,5±0,1	4	1±0,5
10 x 38	38,0±0,6	10,5	10,3±0,1	6	1,5±0,5
14 x 51	51,0+0,6/-1	13,8	14,3±0,1	7,5	±1
22 x 58	58,0+0,1	16,2	22,2±0,1	11	±1

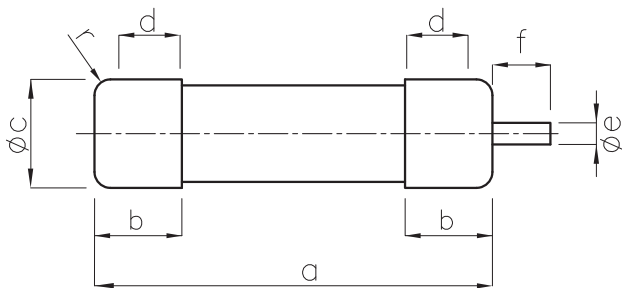

size	e	f
14 x 51	3,8	7,5
22 x 58	3,8	7,5

With striker pin

Technical data - C

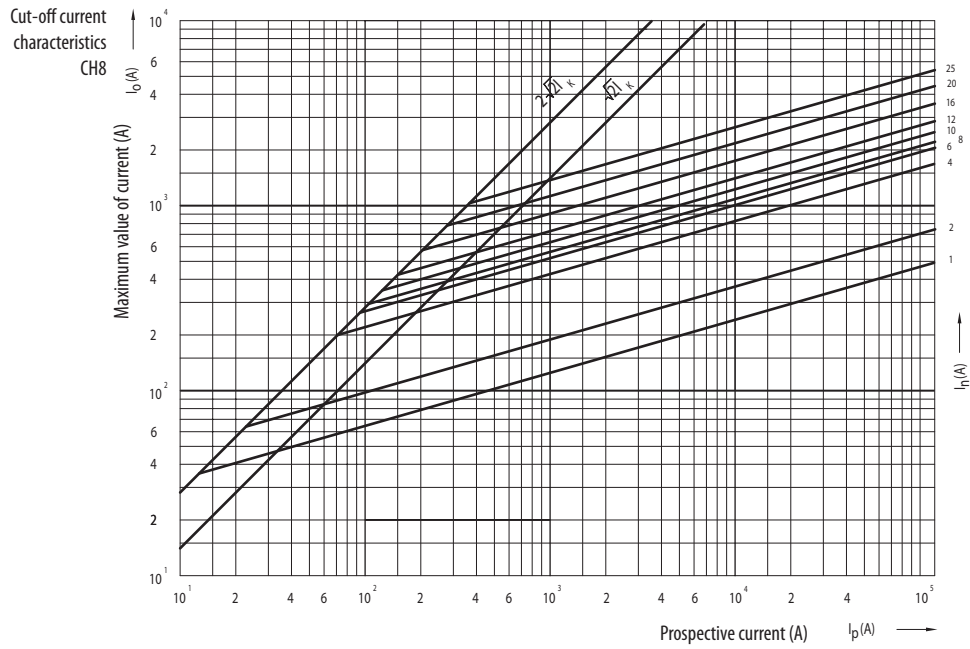
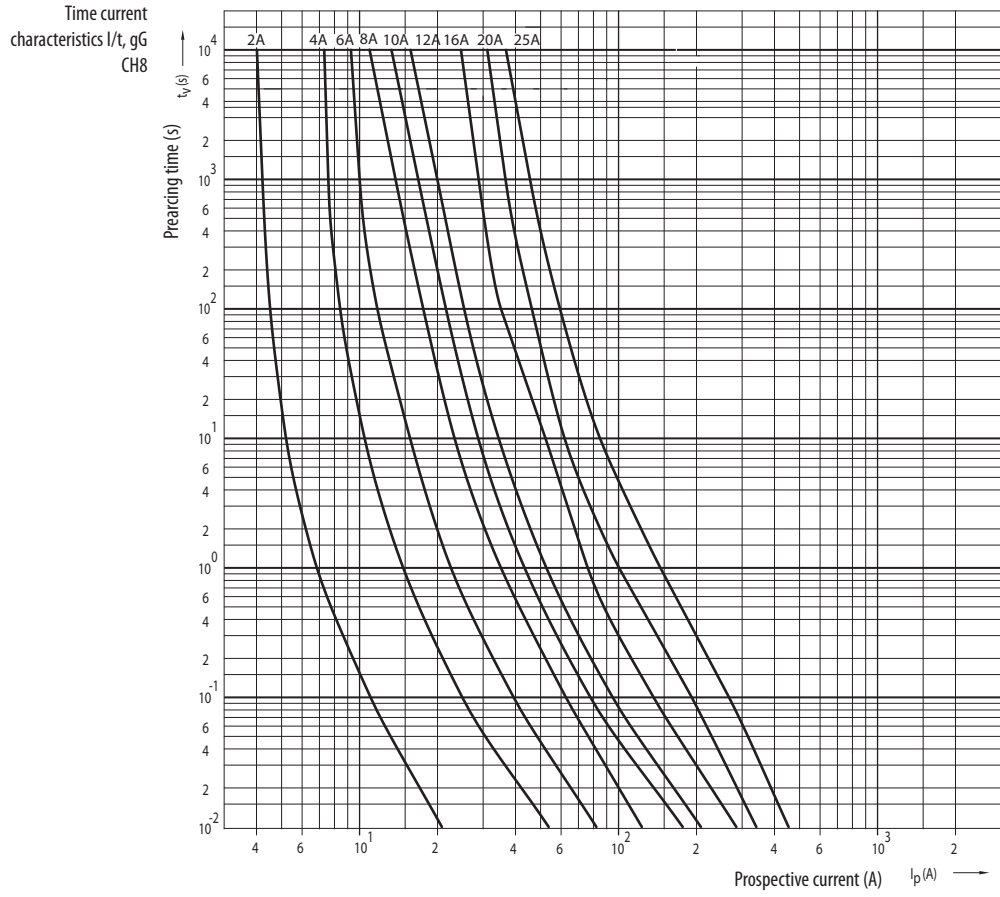

Melting energy characteristics I<sup>2</sup>t CH8

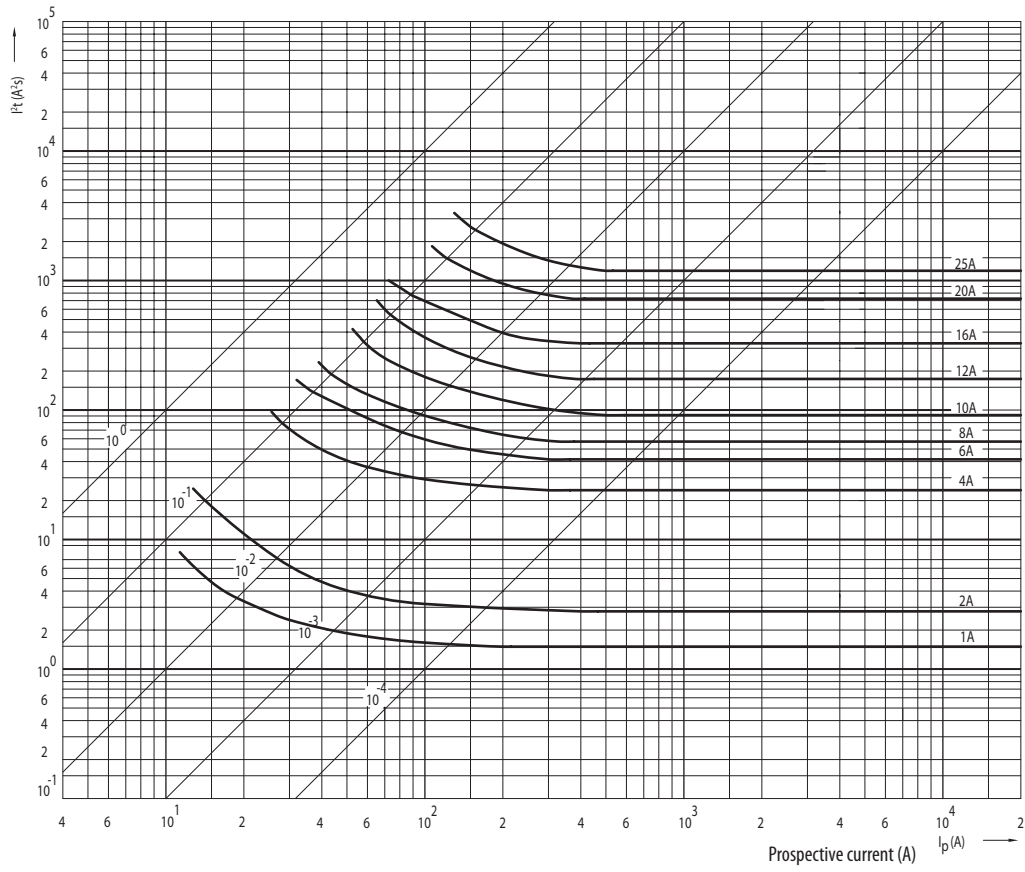

Time current characteristics I/t, gG CH10

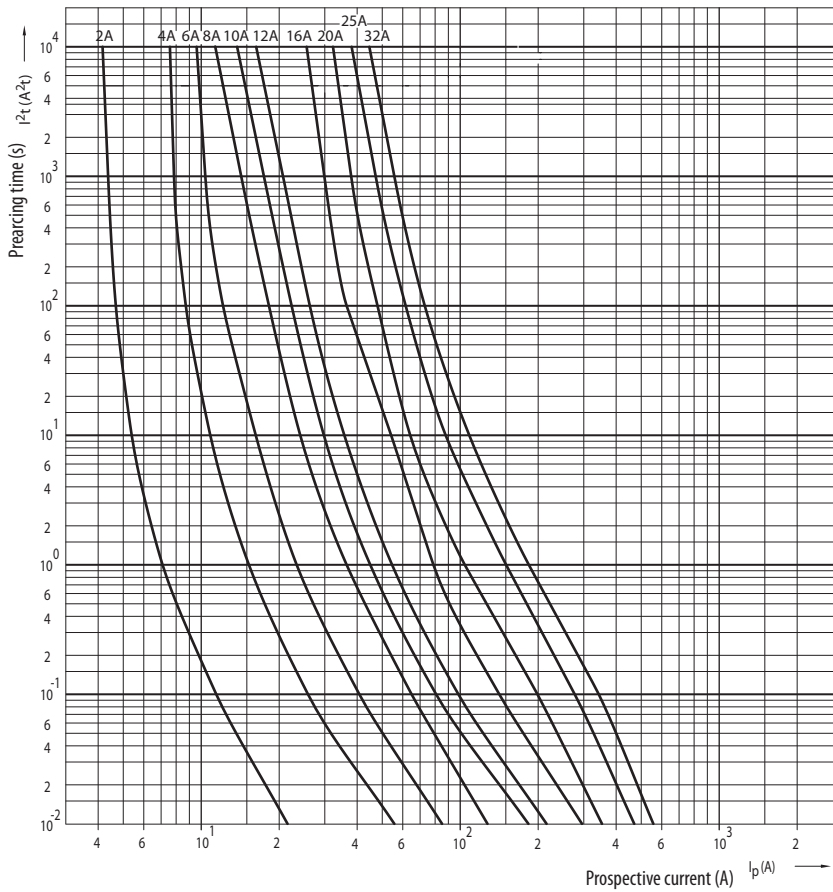

Technical data - C

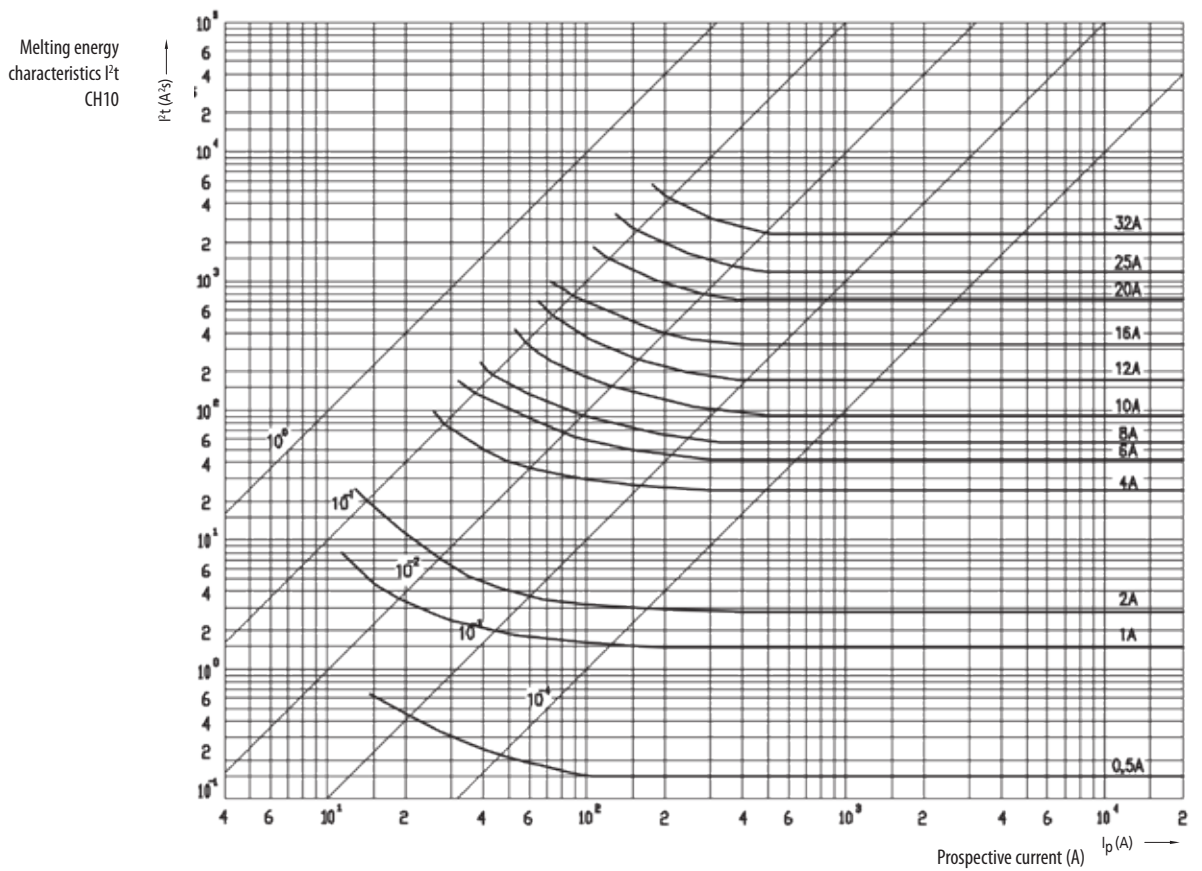
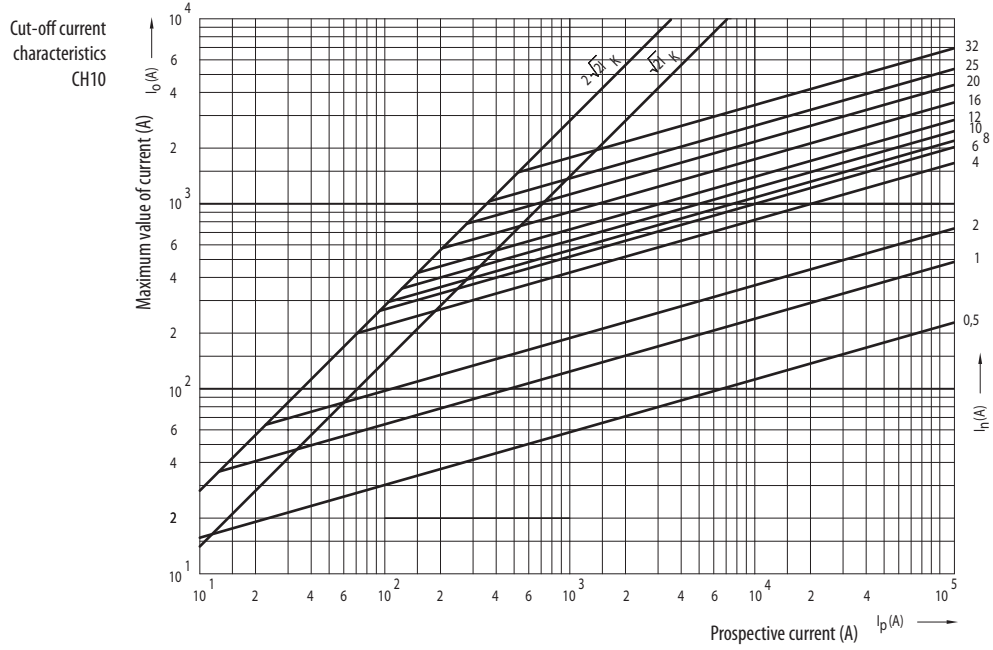

Time current characteristics I/t, gG CH14

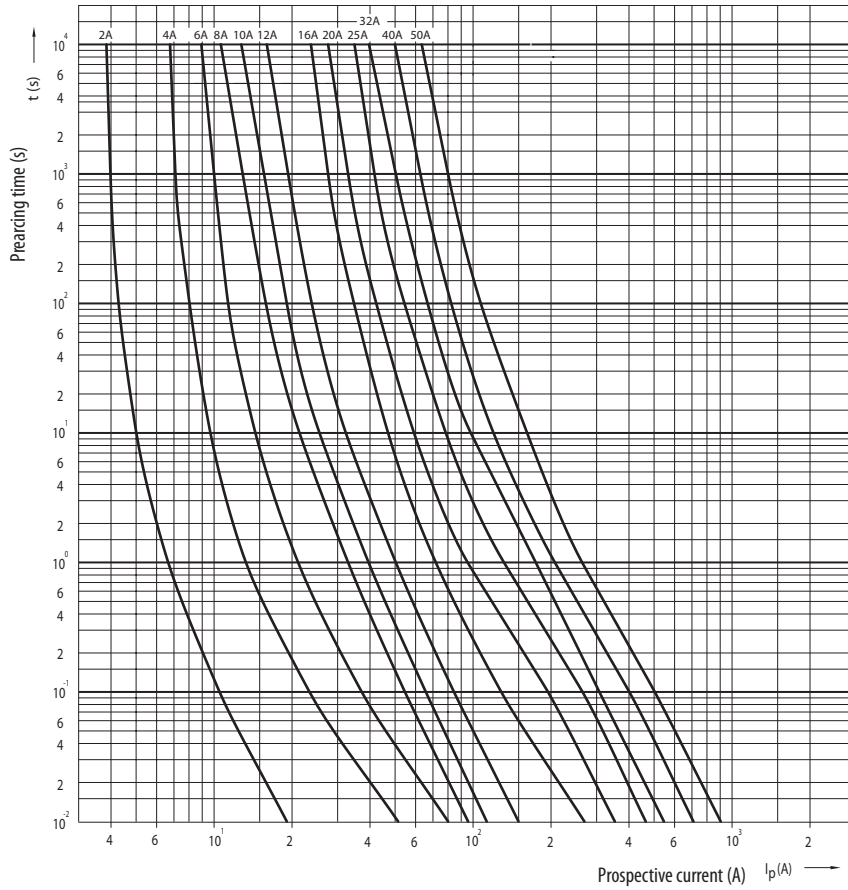

Cut-off current characteristics CH14

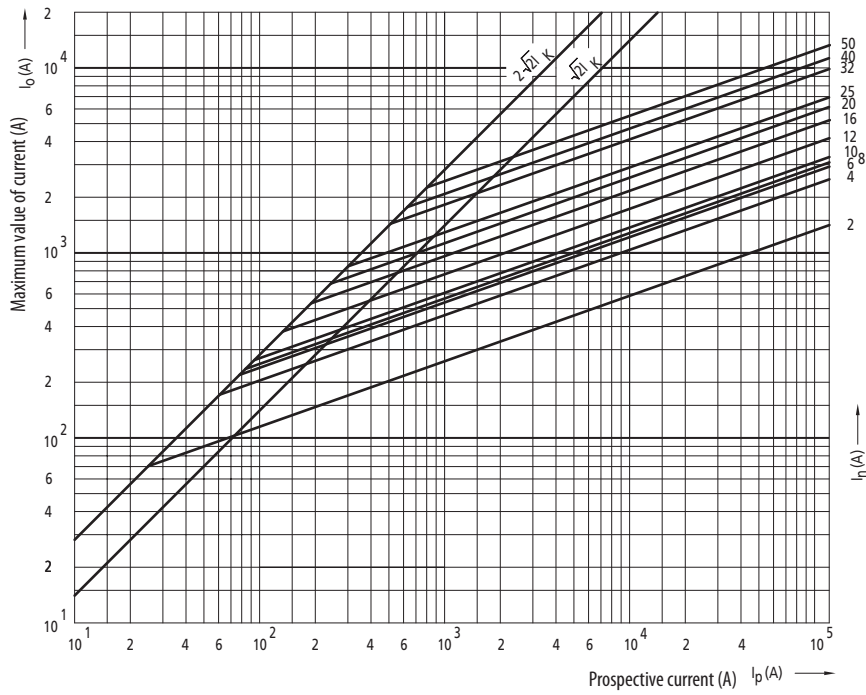

Technical data - C

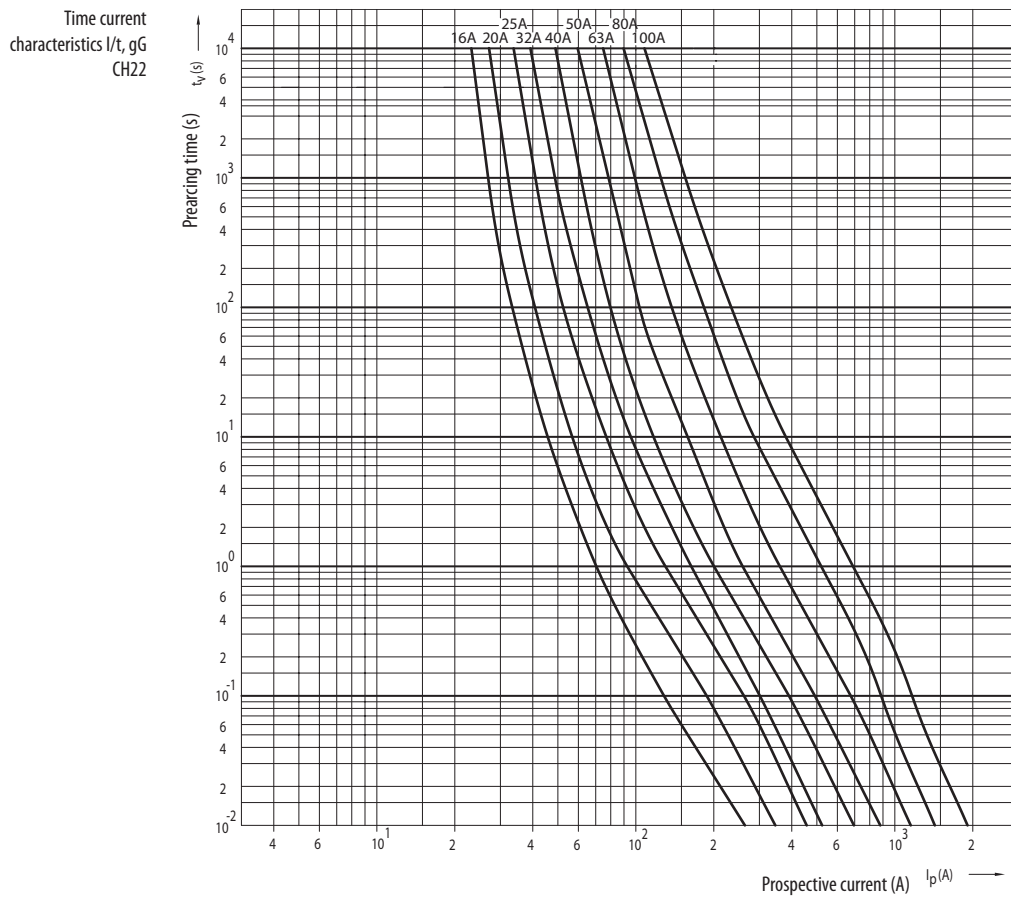
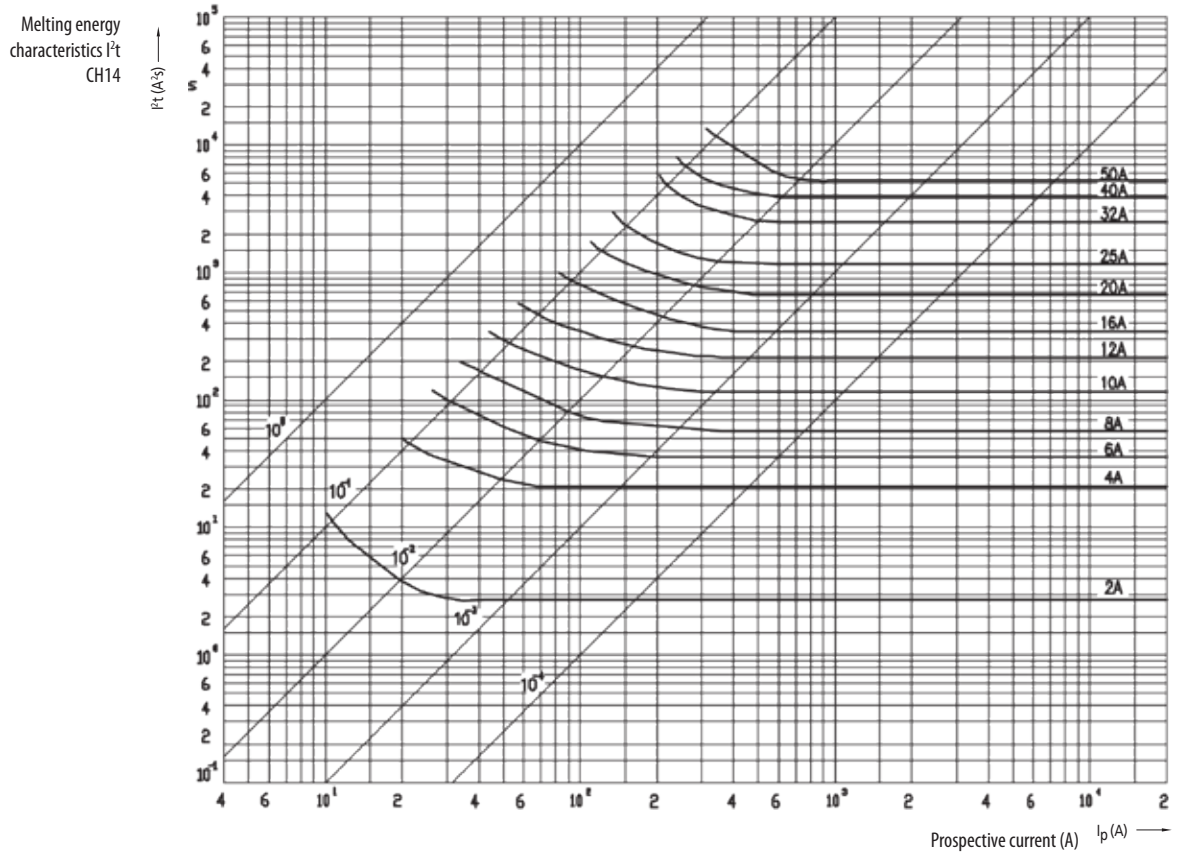

Cut-off current characteristics CH22

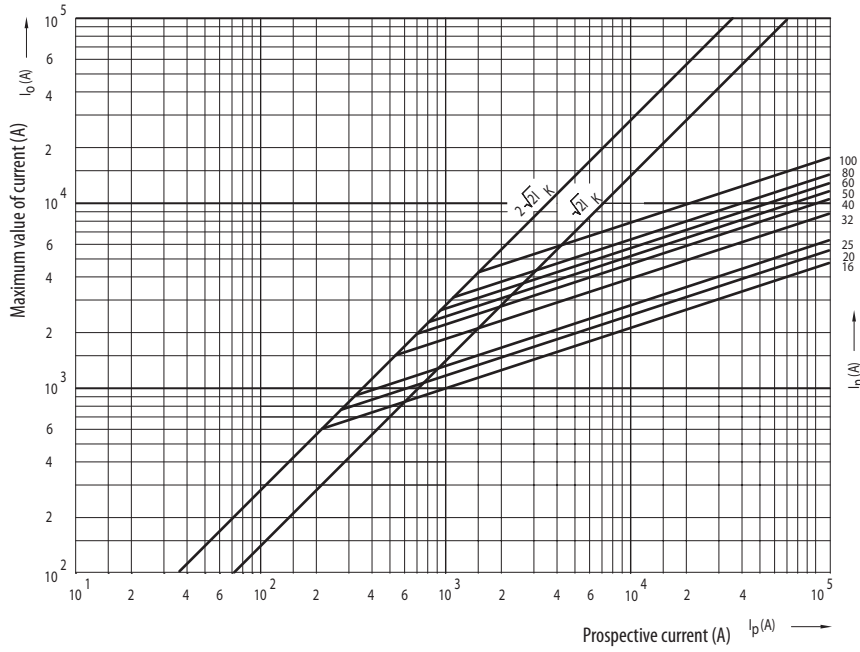

Melting energy characteristics  $I^2t$  CH22

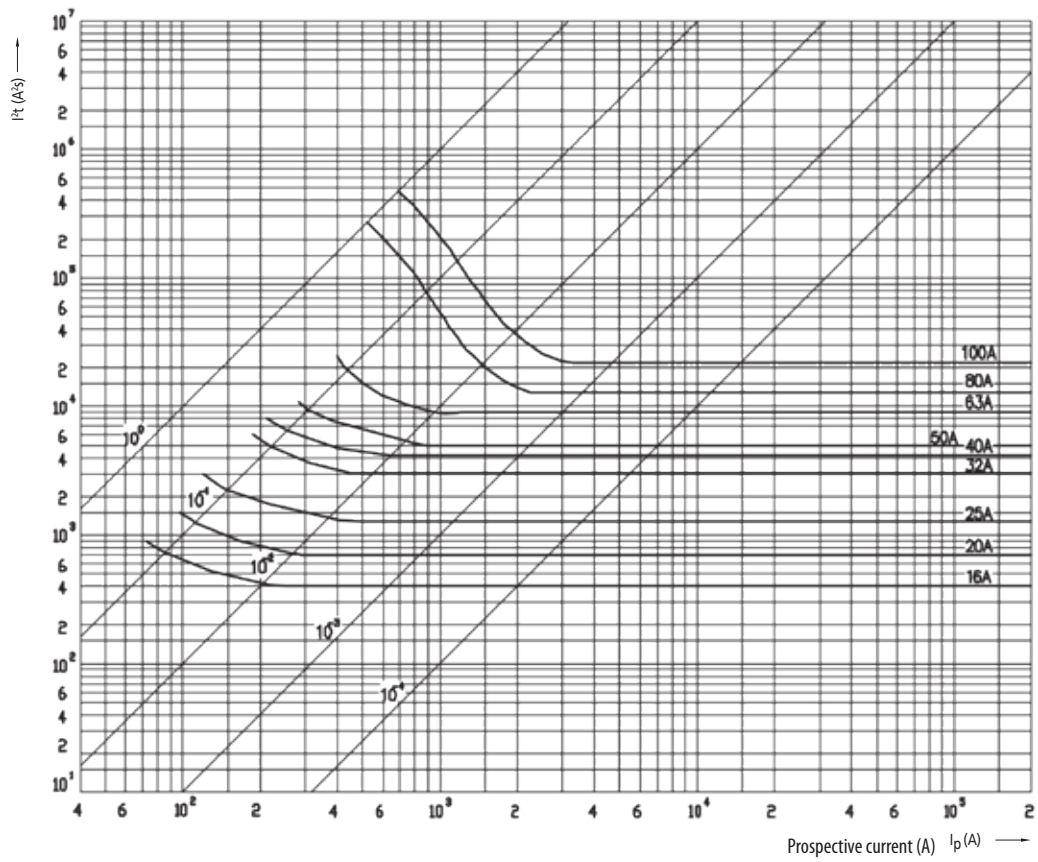

Technical data - C

Time current characteristics I/t, aM CH10, 14, 22

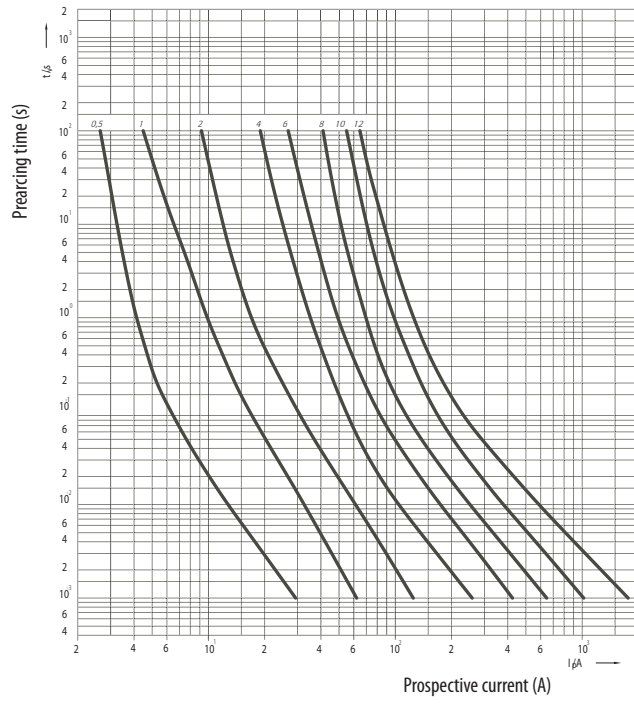

Time current characteristics I/t, aM CH10, 14, 22

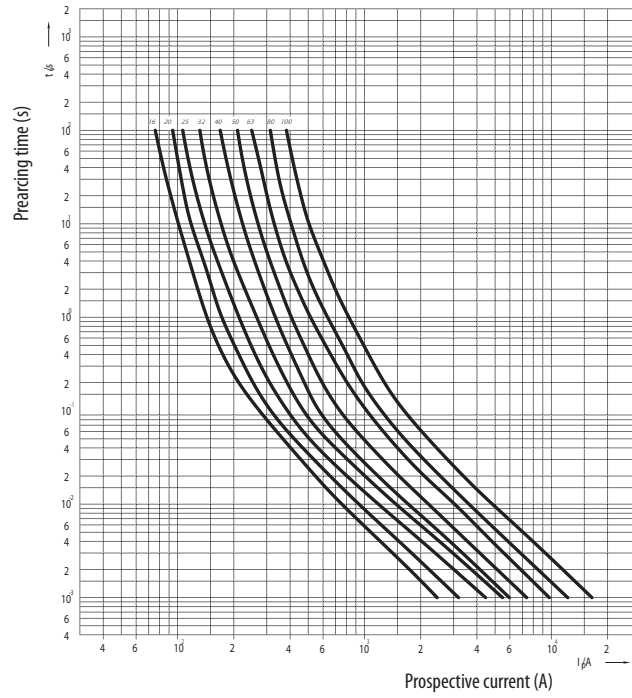

## Fuse disconnectors for cylindrical fuse-links

Technical data							
Type	VLC8	PCF8	VLC10	PCF10	VLC CC	VLC 14	VLC22
Number of poles	1p, 1p+N, 2p, 3p, 3p+N				1p, 2p, 3p	1p, 1p+N, 2p, 3p, 3p+N	
Type of current	a.c.						
Utilization category	AC-22B					AC21-B	
Rated Operational voltage Ue (V)	400	400	400/690 1p+N	400/690 1p+N	600	690	690
Rated frequency (Hz)	50				60	50	
Rated impulse withstand voltage Uimp (kV)	8	4	8	4	8	8	8
Rated operational current (A)	20	20	32	32	30	50	125
Rated short time withstand Icw (A)	240	240	390	390	360	600	1500
Rated conditional short circuit current (kA)	50	100		200		100	
Cage clamps (max mm <sup>2</sup> )	25	10	25	10	25	35	50
Maximal power dissipation (W)	2,5	2,5	3	3	3	5	9,5
Test reports	UL	Int.	CCA/CB, UL, CSA	CCA/CB, UL	Int., UL	CCA/CB, UL, CSA	CCA/CB

## Fuse disconnecter PCF

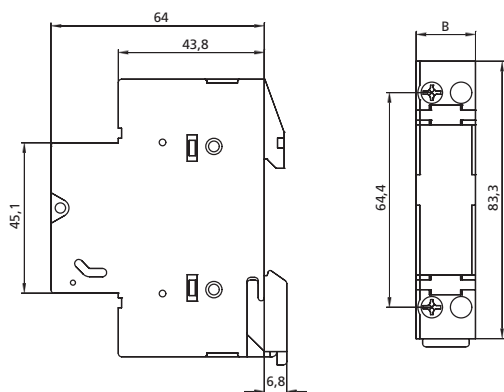

Fuse disconnecter PCF 8, PCF 10

type	dimension
	B
1p	17,8
1p+N	17,8
2p	35,6
3p	53,4
3p+N	53,4

## Auxiliary switch PS PCF

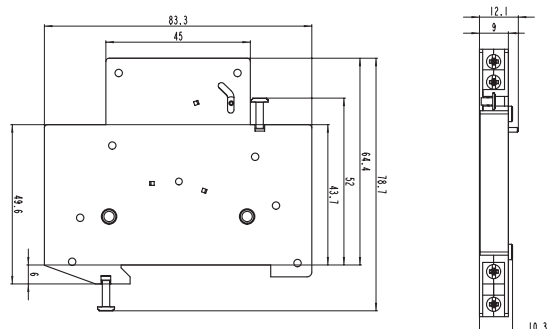

## Fuse disconnecter VLC

### Fuse disconnecter VLC 8, VLC 10

type	dimension B
VLC 8, 10 1p	17,5
VLC 8, 10 1p+N	35
VLC 8, 10 2p	35
VLC 8, 10 3p	52,5
VLC 8, 10 3p+N	70

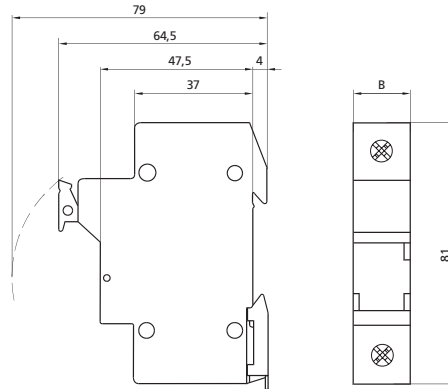

### Fuse disconnecter VLC CC

type	dimension B
VLC CC 1p	17,5
VLC CC 2p	35
VLC CC 3p	52,5

### Fuse disconnecter VLC 14

type	dimension B
VLC 14 1p	27
VLC 14 1p+N	54
VLC 14 2p	54
VLC 14 3p	81
VLC 14 3p+N	108

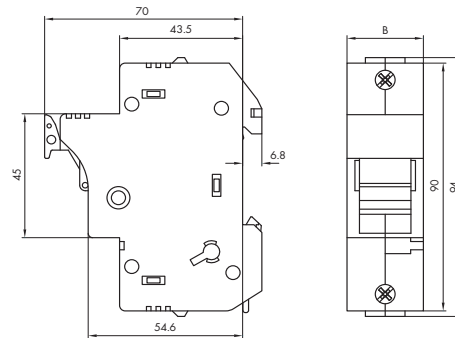

### Fuse disconnecter VLC 22

type	dimension B
VLC 22 1p	35,6
VLC 22 1p+N	71,2
VLC 22 2p	71,2
VLC 22 3p	106,8
VLC 22 3p+N	142,4

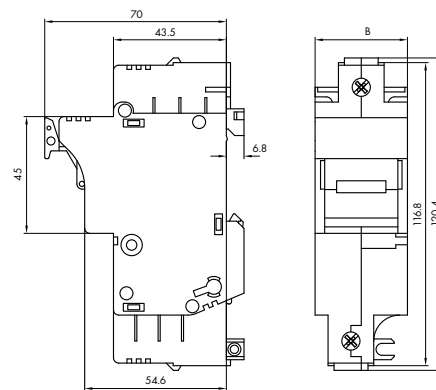

## Auxiliary switch VLC

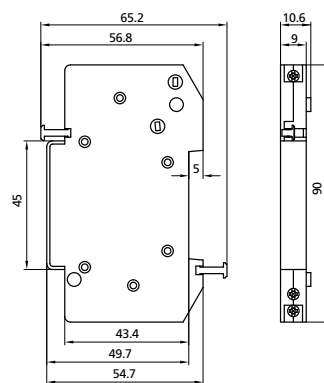

PS VLC 14

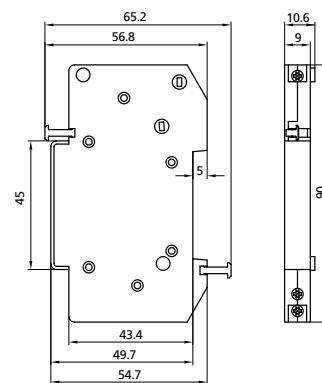

PS VLC 22