

Switch disconnectors LAS

Generalities

The modular switch disconnectors of LAS series allow the breaking and the disconnecting on load of equipment on low voltage at nominal current from 16 A to 125A.

Use

The switch disconnectors of LAS series are commonly used for the following purposes:

- main switch
- switch for motors
- safety switch
- disconnecter

General characteristics

- high breaking capacity (AC 22 A - AC 23 A)
- double break contacts
- high electrical and mechanical endurance
- resistant to damp heat
- IP20 degree of protection
- modular execution, basic mounting on 35 mm DIN rail and by screws, modular window 45mm

Additional poles

Fourth switched pole, solid neutral and earth pole.

Operating mechanism

Black (standard execution) or emergency direct handle padlockable in 0 position.

Handle with and without door interlock handle, black or emergency handle padlock with up to three padlocks in 0 position.

IP 65 degree of protection on door interlock handle.

Switch disconnector LAS

Rated current
16-125 A



Switch disconnector LAS (grey-black handle)

type	code No.	I_n [A]	number of poles	weight [g]	packaging [pcs]
LAS16	004660011	16	3	150	1
LAS25	004660012	25	3	150	1
LAS32	004660013	32	3	150	1
LAS40	004660014	40	3	150	1
LAS63	004660015	63	3	150	1
LAS80	004660106	80	3	265	1
LAS100	004660107	100	3	265	1
LAS125	004660108	125	3	265	1

Switch disconnector LA (yellow-red handle)

type	code No.	I_n [A]	number of poles	weight [g]	packaging [pcs]
LAS16_Y_R	004661011	16	3	150	1
LAS25_Y_R	004661012	25	3	150	1
LAS32_Y_R	004661013	32	3	150	1
LAS40_Y_R	004661014	40	3	150	1
LAS63_Y_R	004661015	63	3	150	1
LAS80_Y_R	004661106	80	3	265	1
LAS100_Y_R	004661107	100	3	265	1
LAS125_Y_R	004661108	125	3	265	1

Door mounting switch disconnector LAS

 Rated current
16-63 A

Door mounting switch disconnector LAS (grey-black handle)

NEW!

type	code No.	I_n [A]	number of poles	weight [g]	packaging [pcs]
LAS16 D	004661200	16	3	130	1
LAS25 D	004661201	25	3	130	1
LAS32 D	004661202	32	3	130	1
LAS40 D	004661203	40	3	130	1
LAS63 D	004661204	63	3	130	1

Door mounting switch disconnector LAS (yellow-red handle)

NEW!

type	code No.	I_n [A]	number of poles	weight [g]	packaging [pcs]
LAS16 DY_R	004661205	16	3	130	1
LAS25 DY_R	004661206	25	3	130	1
LAS32 DY_R	004661207	32	3	130	1
LAS40 DY_R	004661208	40	3	130	1
LAS63 DY_R	004661209	63	3	130	1



Accessories for LAS

Door interlock handle

description	code No.	for use with	weight [g]	packaging [pcs]
ROD LAS_Y_R, emergency, yellow-red	004665002	LAS 16-LAS 125	46	1
ROD LAS, black	004665001	LAS 16-LAS 125	46	1

Shaft

description	code No.	for use with	weight [g]	packaging [pcs]
SH LAS 100, 100mm	004665010	LAS 16-LAS 125	8	1
SH LAS 200, 200mm	004665011	LAS 16-LAS 125	14	1
SH LAS 300, 300mm	004665012	LAS 16-LAS 125	20	1

4th pole

description	code No.	for use with	weight [g]	packaging [pcs]
P4 LAS 16	004665020	LAS 16-LAS 63	52	1
P4 LAS D	004661210	LAS 16 D - LAS 63 D	38	1

Auxiliary contact

description	code No.	for use with	weight [g]	packaging [pcs]
PS LAS 16, 1NO+1NC, screw terminals	004665050	LAS 16-LAS 125	38	1
PS LAS D, 1NO+1NC, faston terminals	004661213	LAS 16 D - LAS 125 D	38	1

Earth pole

description	code No.	for use with	weight [g]	packaging [pcs]
PE LAS 16	004665040	LAS 16-LAS 63	56	1
PE LAS D	004661212	LAS 16 D - LAS 63 D	56	1

Solid neutral

description	code No.	for use with	weight [g]	packaging [pcs]
N LAS 16	004665030	LAS 16-LAS 63	56	1
N LAS D	004661211	LAS 16 D - LAS 63 D	56	1

Terminal cover

description	code No.	for use with	weight [g]	packaging [pcs]
PR LAS 16 3p	004660020	LAS 16-LAS 63	93	1
PR LAS 16 4p	004660021	LAS 16-LAS 63	93	1
PR LAS 80 3p	004665061	LAS 80-LAS 125	93	1
PR LAS 80 za 4p	004665064	LAS 80-LAS 125	93	1



ROD LAS_Y_R



ROD LAS



SH LAS



4th pole



Auxiliary contact



Earth pole



Solid neutral



Terminal covers

Accessories

LAS

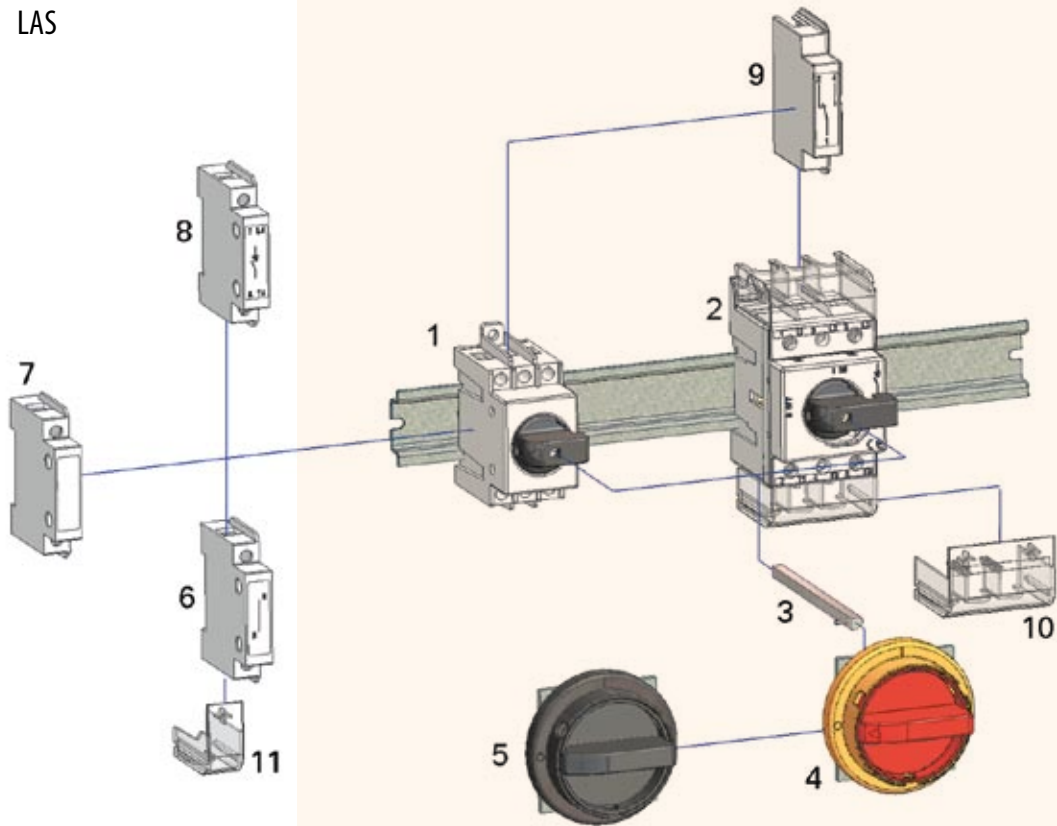

- 1. emergency switch disconnector – direct handle
- 2. emergency switch disconnector – direct handle
- 3. shaft
- 4. emergency door interlock handle (red and yellow)
- 5. door interlock handle (black)
- 6. solid neutral
- 7. earth pole
- 8. 4th pole block
- 9. auxiliary contacts
- 10. terminal cover
- 11. terminal cover for 4th pole

LAS_D

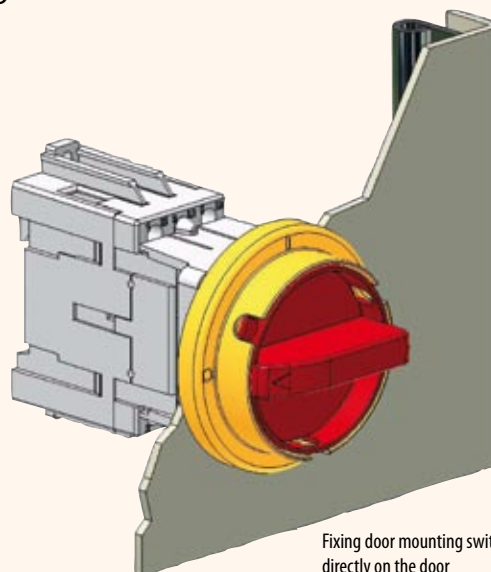

Fixing door mounting switch disconnector directly on the door