

## Industrial distribution box

### Technical data

Material	high-quality thermoplastic mass
Protection classification	
- mechanical	waterproof execution IP 57
- electrical	protection insulation

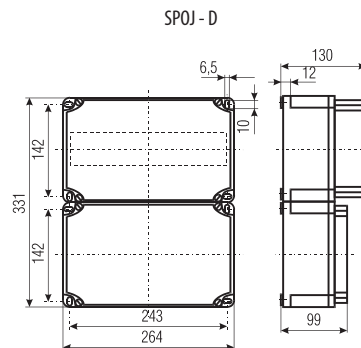
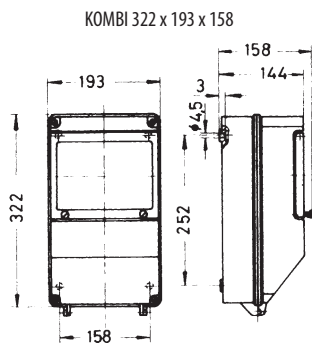
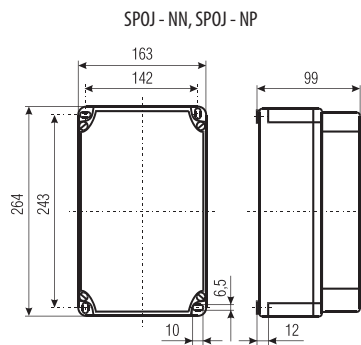
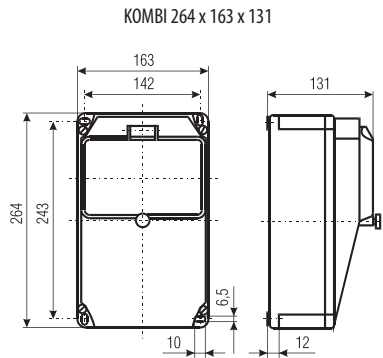
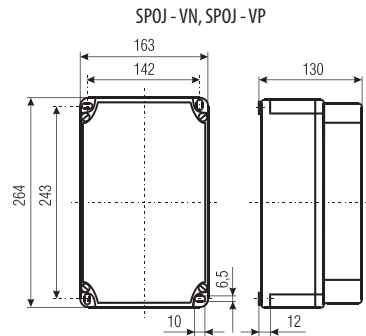

## Industrial plug-in equipment

### Technical data

Rated voltage $U_n$	24 V, 230 V, 400 V
Rated frequency $f_n$	50 Hz
Rated current $I_n$	16 A, 32 A, 63 A, 125 A
Number of poles	2, 3, 4, 5
Standards and regulation	IEC 60309, EN 60309, VDE 0623

### Wall socket on plaster IP 447

**IP 447**

I <sub>n</sub> [A]	number of poles	dimension							
		A	B	C	D	E	F	H	I
16	2P	70	80	113	80	55	11	5,2	5

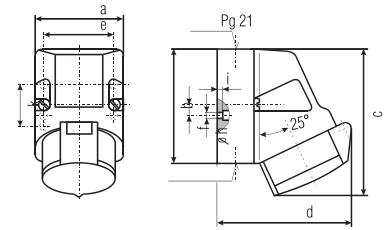

**IP 447**

I <sub>n</sub> [A]	number of poles	dimension										
		A	B	C	D	E	F	H	I	K	L	M
16	2P+⊥	60	90	130	85	62	34	9	6	8	21	72
16	3P+⊥	72,4	90	130	96	77	33,5	9	5,5	9	21	87
16	3P+N+⊥	72,4	90	131	98	77	33,5	9	5,5	9	21	87
32	3P+⊥	79,1	92	142	103	84	30	9	5,5	9	21	94
32	3P+N+⊥	79,1	92	142	106	84	30	9	5,5	9	21	94
32	3P+N+⊥+schuko	79,1	92	142	106	84	30	9	5,5	9	21	94

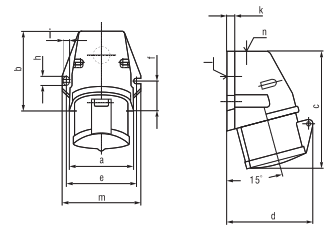

**IP 447**

I <sub>n</sub> [A]	number of poles	dimension							
		A	B	C	D	E	F	H	I
63	3P+⊥	118	170	223	168	104	136	6,1	6
63	3P+N+⊥	118	170	223	168	104	136	6,1	6

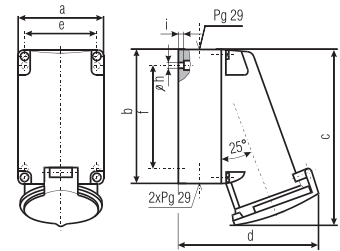

### Wall socket on plaster IP 667

**IP 667**

I <sub>n</sub> [A]	number of poles	dimension									
		A	B	C	D	E	F	H	L	M	
16	2P+⊥	64	87	115	103	51	20	4,1	Pg13,5	Pg16	
16	3P+⊥	75	100	130	110	59	11	5,1	Pg13,5	Pg16	
16	3P+N+⊥	75	100	130	105	59	11	5,1	Pg13,5	Pg16	
32	3P+⊥	83	126	160	129	65	11	5,5	2xPg21	Pg21	
32	3P+N+⊥	83	126	160	135	65	11	5,5	2xPg21	Pg21	

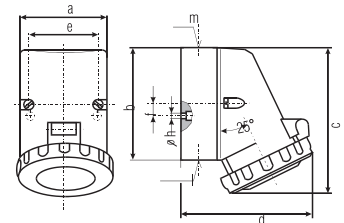

### Wall socket on plaster IP 667

**IP 667**

I <sub>n</sub> [A]	number of poles	dimension									
		A	B	C	D	E	F	H	I	L	M
63	3P+⊥	118	170	228	176	104	136	6,1	6	2Pg29	Pg29
63	3P+N+⊥	118	170	228	176	104	136	6,1	6	2Pg29	Pg29
125	3P+⊥	160	260	330	168	140	240	8,3	10	-	Pg42
125	3P+N+⊥	160	260	330	168	140	240	8,3	10	-	Pg42

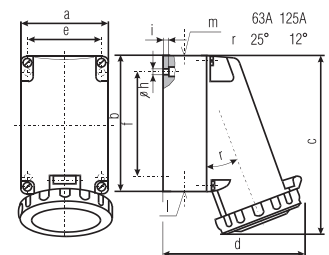

### Built-in wall socket IP 447

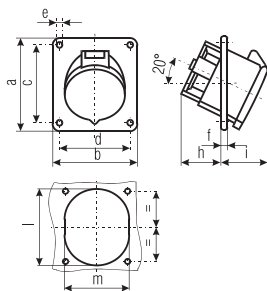

IP 447											
I <sub>n</sub> [A]	number of poles	dimension									
		A	B	C	D	E	F	H	I	L	M
16	2P	68	62	53	47	5,2	6	36	35	56	52
16	Schuko	62	50	38	38	4,2	3	30	15	43	43
16	2P+⊥	74	62	60	52	5,5	8	30	48	57	52
16	3P+⊥	85	85	70	70	5,5	8	30	50	65	65
16	3P+N+⊥	85	85	70	70	5,5	8	30	60	70	70
32	3P+⊥	85	85	70	70	5,5	8	34	58	78	78
32	3P+N+⊥	85	85	70	70	5,5	8	34	60	78	78

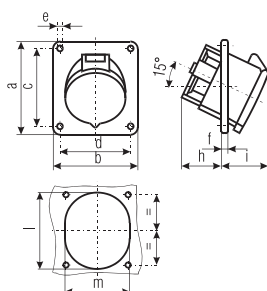

IP 447											
I <sub>n</sub> [A]	number of poles	dimension									
		A	B	C	D	E	F	H	I	L	M
63	3P+⊥	114	114	90	90	6,5	12	65	67,5	92	92
63	3P+N+⊥	114	114	90	90	6,5	12	65	67,5	92	92

### Built-in wall socket IP 667

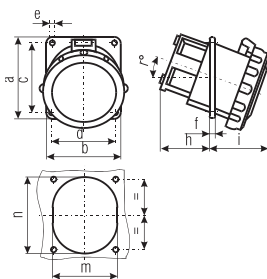

IP 667												
I <sub>n</sub> [A]	number of poles	dimension										
		A	B	C	D	E	F	H	I	R	M	N
16	2P+⊥	74	62	60	52	5,5	8	30	55	20	52	57
16	3P+⊥	100	92	85	77	5,5	8	28,5	57,5	20	65	65
16	3P+N+⊥	100	92	85	77	5,5	8	29	60	20	70	70
32	3P+⊥	100	92	85	77	5,5	8	42	62	20	75	75
32	3P+N+⊥	100	92	85	77	5,5	8	34	69	20	78	78
63	3P+⊥	114	114	90	90	6,5	12	65	80	15	92	92
63	3P+N+⊥	114	114	90	90	6,5	12	65	80	15	92	92

### Plug in socket IP 447 flexible leading-in

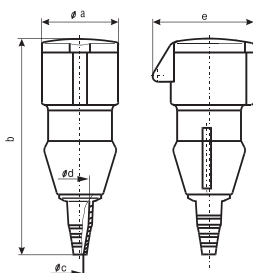

IP 447						
I <sub>n</sub> [A]	number of poles	dimension				
		A	B	C	D	E
16	2P	62	158	7	24,5	67
16	2P+⊥	51	172	7	17,5	71
16	3P+⊥	58	173	7	17,5	79
16	3P+N+⊥	65	177	7	17,5	85
32	3P+⊥	66	225	10	26	93
32	3P+N+⊥	72	226	10	26	99

### Plug-in socket IP 447 threaded leading-in

I <sub>n</sub> [A]	number of poles	dimension			
		A	B	C	D
63	3P+⊥	95,5	271	108	36,5
63	3P+N+⊥	95,5	271	108	36,5

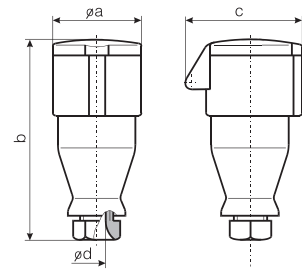

### Plug-in socket IP 677

**IP 667**

I <sub>n</sub> [A]	number of poles	dimension			
		A	B	C	D
16	2P+⊥	70,5	153	77	16
16	3P+⊥	78	153	83	16
16	3P+N+⊥	86,5	159	93	16
32	3P+⊥	94	188	99	22,5
32	3P+N+⊥	101,5	188	107	22,5
63	3P+⊥	110	272	113,5	36,5
63	3P+N+⊥	110	272	113,5	36,5
125	3P+⊥	126	308	128	44
125	3P+N+⊥	126	308	128	44

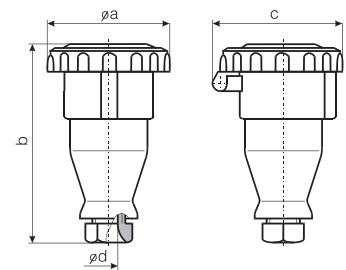

### Plug-in socket IP 447 flexible leading-in

I <sub>n</sub> [A]	number of poles	dimension				
		A	B	C	D	E
16	2P	62	145	123	7	24,5
16	2P+⊥	51	161	125	7	17,5
16	3P+⊥	58	161	125	7	17,5
16	3P+N+⊥	64	166	130	7	17,5
32	3P+⊥	66	212	167	10	26
32	3P+N+⊥	73	213	168	10	26

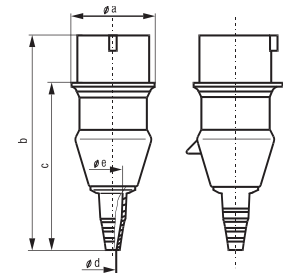

### Plug IP 447 threaded leading-in

I <sub>n</sub> [A]	number of poles	dimension				
		A	B	C	D	E
63	3P+⊥	103	226	254	188	37
63	3P+N+⊥	103	226	254	188	37

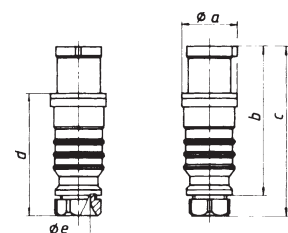

### Plug IP 677

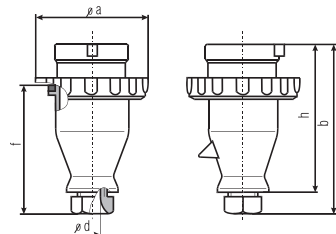

I <sub>n</sub> [A]	number of poles	dimension				
		A	B	D	F	H
16	2P+⊥	70,5	139	16	105,5	112
16	3P+⊥	78	139	16	105,5	112
16	3P+N+⊥	86,5	145	16	111,5	118
32	3P+⊥	94	171	22,5	127	144
32	3P+N+⊥	101,5	171	22,5	127	144
63	3P+⊥	113,5	254	36	192	226
63	3P+N+⊥	113,5	254	36	192	226
125	3P+⊥	125	286	44	215	253
125	3P+N+⊥	125	286	44	215	253

### Plug for appliances IP 447

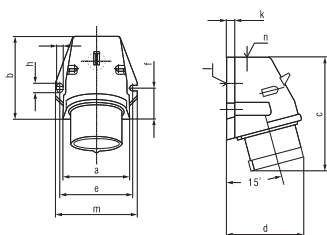

I <sub>n</sub> [A]	number of poles	dimension											
		A	B	C	D	E	F	H	I	K	L	M	N
16	2P	-	80	100	82	55	51	-	-	-	5,2	70	Pg21
16	2P+⊥	-	60	93	73	30	37	-	-	-	5,5	57	Pg16
16	3P+⊥	72,4	90	120	84	77	33,5	9	5,5	9	21	87	Pg16
16	3P+N+⊥	72,4	90	120	84	77	33,5	9	5,5	9	21	87	Pg16
32	3P+⊥	79,1	92	134	89	84	30	9	5,5	9	21	94	Pg21
32	3P+N+⊥	79,1	92	134	89	84	30	9	5,5	9	21	94	Pg21

### Built-in plug IP 447

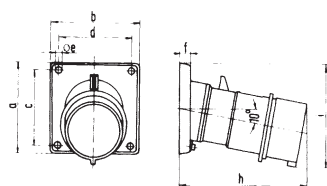

I <sub>n</sub> [A]	number of poles	dimension							
		A	B	C	D	E	F	H	I
16	2P+⊥	85	85	70	70	6,3	11	104	83
16	3P+⊥	85	85	70	70	6,3	11	110	90
16	3P+N+⊥	85	85	70	70	6,3	11	116	92
32	3P+⊥	85	85	70	70	6,3	11	121	96
32	3P+N+⊥	85	85	70	70	6,3	11	127	100

#### Minimum and maximum conductor cross section, depending on the rated current

I <sub>n</sub> [A]	S <sub>min</sub> [mm <sup>2</sup> ]	S <sub>max</sub> [mm <sup>2</sup> ]
16	1,5	4
32	2,5	10
63	6	25
125	25	70

## Line-up terminal

### Terminal's elements

#### Insulation part

The material of the insulating body of the terminals type VS PA is PA 6.6 polyamide (self-extinguishable - colour of ebony acc. to RAL 1014) which is made of polyamide resin and has higher temperature resistance, it is thermal stabilized and is resistant to aging. Polyamide 6.6 has good geometrical stability and excellent mechanical resistance. The material satisfies regulation according to IEC 695-2-1. It is suitable for use in temperature range from -40 C to +100 C according to IEC 216 rules. In the mentioned range the material remains unchanged. It is resistant to oils, greases, salts, several alkaline solutions and to low percentage of acid concentration. It is resistant to micro-organisms, bacteria, fungi, enzymes and termites. The design of the insulation body of the terminal consider the regulations of air and creepage distances of nominal voltage according IEC 947-1.

#### Terminal body

The terminal body of 2,5 mm<sup>2</sup> connecting elements are made from brass, others are made from steel. The body is equipped with a hole with thread for obtaining screw pressure. In the final phase of the production the bodies of brass are treated by coating with Ni and other are treated by coating with 12 microns of zinc and with blue pasivation. In this way galvanically and corrosion protection is obtained. The terminal body has excellent mechanical characteristics and they are not subject to mechanical deformation in ordinary use, which are prescribed with IEC 947-1 regulations. Terminal bodies are equipped with body nose (except terminal body VS 2.5 PA). So, it is avoided to insert cable under body if the terminal body is closed or half closed.

#### Conducting bar

The conducting bar is made of copper and is galvanically protected with 6 microns tin in surface. The coating provides ideal conducting characteristics and better surface contact, at the same time the corrosion effect is reduced.

#### Conducting bushes

They are made of brass containing a high percentage of copper and they are protected against atmospheric corroding agents, chemical corrosion and marine corrosion by galvanic treatment.

#### Screws

The screws are made of steel, treated to have a hard coating and they obtain a high tightening torque. Screws are equipped with metric threads according ISO and are galvanically protected against corrosion with 8 microns zinc. Screws are designed to sustain mechanical tightening torque according to IEC 947-1.

### Current carrying capacity of conduct

The table below lists the test currents of the individual conductor cross sections as specified in the European standard IEC 947-7-1. Terminal blocks that are tested with this load must maintain the tolerance limits specified in the standard (e.g. maximum temperature rise).

**Test currents in acc. with IEC 947-7-1 table V**

Rated cross section [mm <sup>2</sup> ]	0,5	0,75	1	1,5	2,5	4	6	10	16
Test current [A]	6	9	13,5	17,5	24	32	41	57	76
Rated cross section [mm <sup>2</sup> ]	25	35	50	70	95	120	150	185	240
Test current [A]	101	125	150	192	232	269	309	353	415

#### Tightening screw torque of terminal blocks

IEC 947-7-1 specifies mechanical tests for judging the quality of the connection elements. According to these tests conductors should be connected by tightening the terminal block screws with a certain torque. The value of the torque depends on the dimensions of the terminal block screw and is shown in the table below. The relatively low torque allows safe connections.

**Extract from IEC 947-1 table IV**

Thread	Head screw with slot		Head screw without slot - hexagon nut	
	Tightening torque [Nm]	Maximal tightening torque [Nm] Steel screw	Steel screw	
M2,5	0,4	0,7	-	-
M 3	0,5	1,0	-	-
M 3,5	0,8	1,4	-	-
M 4	1,2	2,0	1,2	2,0
M 5	2,0	4,0	2,0	4,0
M 6	2,5	5,0	3,0	6,0
M 8	3,5	-	6,0	12,0
M 10	4,0	-	10,0	20,0

**Line-up terminal VS 2,5 PA**

dimensions	
thickness of terminal [mm]	5
av. tolerance of engaging on terminals rail [mm]	+0,1
stripping length of conductor [mm]	7
cross-section of conductors	
cross-section of single wire [mm <sup>2</sup> ]	0,5-4,0
cross-section of fine wire [mm <sup>2</sup> ]	0,5-2,5
cross-section of fine wire [mm <sup>2</sup> ]	0,5-2,5
cross-section of multiple wire [mm <sup>2</sup> ]	0,4-25
nominal value (IEC 947-1)	
nominal voltage [V]	660
nominal current [A]	24
nominal cross-section [mm <sup>2</sup> ]	2,5

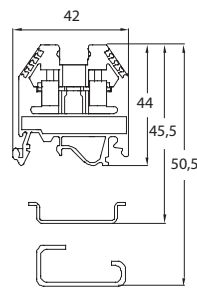

M3

**Line-up terminal VS 4 PA**

dimensions	
thickness of terminal [mm]	6
av. tolerance of engaging on terminals rail [mm]	+0,1
stripping length of conductor [mm]	7
cross-section of conductors	
cross-section of single wire [mm <sup>2</sup> ]	1,5-6,0
cross-section of fine wire [mm <sup>2</sup> ]	1,5-4,0
cross-section of fine wire [mm <sup>2</sup> ]	1,5-4,0
cross-section of multiple wire [mm <sup>2</sup> ]	1,5-4,0
nominal value (IEC 947-1)	
nominal voltage [V]	660
nominal current [A]	32
nominal cross-section [mm <sup>2</sup> ]	4,0

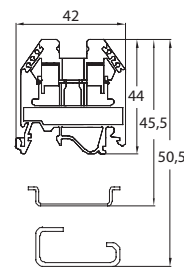

M3

**Line-up terminal VS 6 PA**

dimensions	
thickness of terminal [mm]	8
av. tolerance of engaging on terminals rail [mm]	+0,1
stripping length of conductor [mm]	9
cross-section of conductors	
cross-section of single wire [mm <sup>2</sup> ]	1,5-10,0
cross-section of fine wire [mm <sup>2</sup> ]	2,5-6,0
cross-section of fine wire [mm <sup>2</sup> ]	2,5-6,0
cross-section of multiple wire [mm <sup>2</sup> ]	2,5-6,0
nominal value (IEC 947-1)	
nominal voltage [V]	660
nominal current [A]	41
nominal cross-section [mm <sup>2</sup> ]	6,0

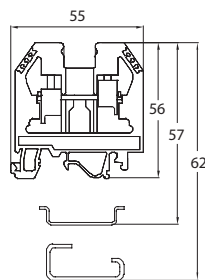

M3

**Line-up terminal VS 10 PA**

dimensions	
thickness of terminal [mm]	10
av. tolerance of engaging on terminals rail [mm]	+0,1
stripping length of conductor [mm]	10
cross-section of conductors	
cross-section of single wire [mm <sup>2</sup> ]	2,5-10,0
cross-section of fine wire [mm <sup>2</sup> ]	4,0-10,0
cross-section of fine wire [mm <sup>2</sup> ]	2,5-10,0
cross-section of multiple wire [mm <sup>2</sup> ]	4,0-10,0
nominal value (IEC 947-1)	
nominal voltage [V]	660
nominal current [A]	57
nominal cross-section [mm <sup>2</sup> ]	10,0

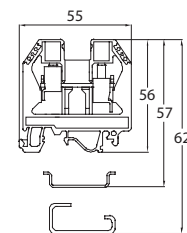

M4

## Technical data - SPOJ

### Line-up terminal VS 16 PA

dimensions	
thickness of terminal [mm]	12
av. tolerance of engaging on terminals rail [mm]	+0,1
stripping length of conductor [mm]	11
cross-section of conductors	
cross-section of single wire [mm <sup>2</sup> ]	4-16
cross-section of fine wire [mm <sup>2</sup> ]	6-16
cross-section of fine wire [mm <sup>2</sup> ]	4-16
cross-section of multiple wire [mm <sup>2</sup> ]	10-25
nominal value (IEC 947-1)	
nominal voltage [V]	660
nominal current [A]	76
nominal cross-section [mm <sup>2</sup> ]	16

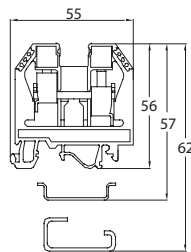

M4

### Line-up terminal VS 35 PA

dimensions	
thickness of terminal [mm]	16
av. tolerance of engaging on terminals rail [mm]	+0,1
stripping length of conductor [mm]	15
cross-section of conductors	
cross-section of single wire [mm <sup>2</sup> ]	6-35
cross-section of fine wire [mm <sup>2</sup> ]	10-35
cross-section of fine wire [mm <sup>2</sup> ]	6-35
cross-section of multiple wire [mm <sup>2</sup> ]	10-50
nominal value (IEC 947-1)	
nominal voltage [V]	660
nominal current [A]	125
nominal cross-section [mm <sup>2</sup> ]	35

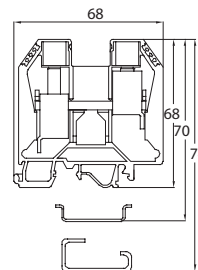

M6

### Line-up terminal VS 70 PA

dimensions	
thickness of terminal [mm]	20
av. tolerance of engaging on terminals rail [mm]	+0,2
stripping length of conductor [mm]	20
cross-section of conductors	
cross-section of single wire [mm <sup>2</sup> ]	10-35
cross-section of fine wire [mm <sup>2</sup> ]	10-70
cross-section of fine wire [mm <sup>2</sup> ]	10-35
cross-section of multiple wire [mm <sup>2</sup> ]	10-95
nominal value (IEC 947-1)	
nominal voltage [V]	660
nominal current [A]	192
nominal cross-section [mm <sup>2</sup> ]	70

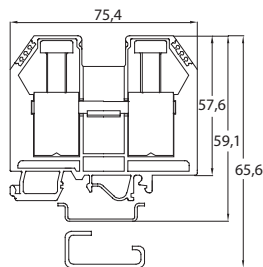

M8

### Sensor terminal block VS 2,5 IN

dimensions	
thickness of terminal [mm]	5,1
av. tolerance of engaging on terminals rail [mm]	+0,2
stripping length of conductor [mm]	8
cross-section of conductors	
cross-section of single wire [mm <sup>2</sup> ]	0,3-4
cross-section of fine wire [mm <sup>2</sup> ]	0,3-2,5
nominal value (IEC 947-1)	
nominal voltage [V]	440
nominal current [A]	24
nominal cross-section [mm <sup>2</sup> ]	2,5

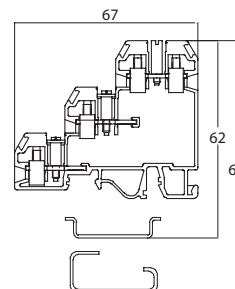

M3

Double level line-up terminal VS 2,5 NA	
dimensions	
thickness of terminal [mm]	5
av. tolerance of engaging on terminals rail [mm]	+0,1
stripping length of conductor [mm]	8
cross-section of conductors	
cross-section of single wire [mm <sup>2</sup> ]	0,3-4,0
cross-section of fine wire [mm <sup>2</sup> ]	0,3-2,5
nominal value (IEC 947-1)	
nominal voltage [V]	440
nominal current [A]	24
nominal cross-section [mm <sup>2</sup> ]	2,5

Double level line-up terminal VS 4 NA	
dimensions	
thickness of terminal [mm]	6
av. tolerance of engaging on terminals rail [mm]	+0,1
stripping length of conductor [mm]	8
cross-section of conductors	
cross-section of single wire [mm <sup>2</sup> ]	0,3-6,0
cross-section of fine wire [mm <sup>2</sup> ]	0,3-4,0
nominal value (IEC 947-1)	
nominal voltage [V]	440
nominal current [A]	32
nominal cross-section [mm <sup>2</sup> ]	4

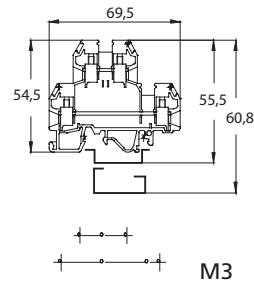
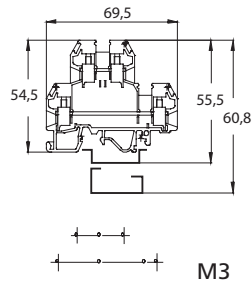

Double level line-up terminal VS 4 NA1	
dimensions	
thickness of terminal [mm]	6
av. tolerance of engaging on terminals rail [mm]	+0,1
stripping length of conductor [mm]	8
cross-section of conductors	
cross-section of single wire [mm <sup>2</sup> ]	0,3-6,0
cross-section of fine wire [mm <sup>2</sup> ]	0,3-4,0
nominal value (IEC 947-1)	
nominal voltage [V]	440
nominal current [A]	32
nominal cross-section [mm <sup>2</sup> ]	4

Three level line-up terminal VS 2,5 NA3	
dimensions	
thickness of terminal [mm]	6
av. tolerance of engaging on terminals rail [mm]	+0,1
stripping length of conductor [mm]	8
cross-section of conductors	
cross-section of single wire [mm <sup>2</sup> ]	0,3-4,0
cross-section of fine wire [mm <sup>2</sup> ]	0,3-2,5
nominal value (IEC 947-1)	
nominal voltage [V]	440
nominal current [A]	24
nominal cross-section [mm <sup>2</sup> ]	2,5

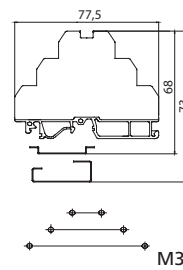
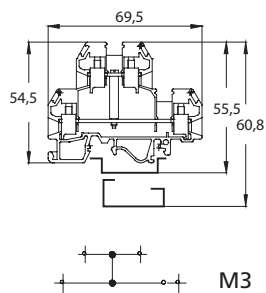

## Technical data - SPOJ

### Three level line-up terminal VS 2,5 NAI3

dimensions	
thickness of terminal [mm]	6
av. tolerance of engaging on terminals rail [mm]	+0,1
stripping length of conductor [mm]	8
cross-section of conductors	
cross-section of single wire [mm <sup>2</sup> ]	0,3-4,0
cross-section of fine wire [mm <sup>2</sup> ]	0,3-2,5
nominal value (IEC 947-1)	
nominal voltage [V]	440
nominal current [A]	24
nominal cross-section [mm <sup>2</sup> ]	2,5

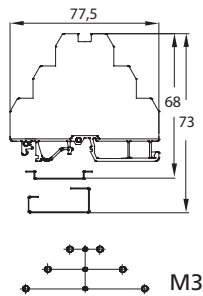

### Line-up terminal with fuse holder VSV 4

dimensions	
thickness of terminal [mm]	8
av. tolerance of engaging on terminals rail [mm]	+0,2
stripping length of conductor [mm]	7
cross-section of conductors	
cross-section of single wire [mm <sup>2</sup> ]	1,4-4,0
cross-section of fine wire [mm <sup>2</sup> ]	0,3-4,0
nominal value (IEC 947-1)	
nominal voltage [V]	440
nominal current [A]	32
nominal cross-section [mm <sup>2</sup> ]	4

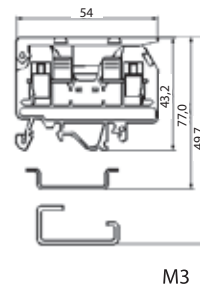

### Multi level line-up terminal with ground VS 2,5 PE2

dimensions	
thickness of terminal [mm]	6
av. tolerance of engaging on terminals rail [mm]	+0,1
stripping length of conductor [mm]	8
cross-section of conductors	
cross-section of single wire [mm <sup>2</sup> ]	0,3-2,5
cross-section of fine wire [mm <sup>2</sup> ]	0,3-4,0
nominal value (IEC 947-1)	
nominal voltage [V]	440
nominal current [A]	32
nominal cross-section [mm <sup>2</sup> ]	4

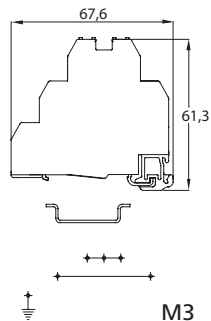

### Multi level line-up terminal with ground VS 2,5 PE3

dimensions	
thickness of terminal [mm]	6
av. tolerance of engaging on terminals rail [mm]	+0,1
stripping length of conductor [mm]	8
cross-section of conductors	
cross-section of single wire [mm <sup>2</sup> ]	0,3-2,5
cross-section of fine wire [mm <sup>2</sup> ]	0,3-4,0
nominal value (IEC 947-1)	
nominal voltage [V]	440
nominal current [A]	32
nominal cross-section [mm <sup>2</sup> ]	4

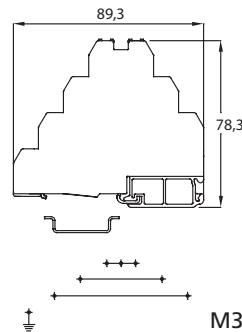

**Mini line-up terminal VS 2,5 PAM**

dimensions	
thickness of terminal [mm]	5,1
av. tolerance of engaging on terminals rail [mm]	+0,2
stripping length of conductor [mm]	8
cross-section of conductors	
cross-section of single wire [mm <sup>2</sup> ]	0,3-4,0
cross-section of fine wire [mm <sup>2</sup> ]	0,3-2,5
nominal value (IEC 947-1)	
nominal voltage [V]	440
nominal current [A]	24
nominal cross-section [mm <sup>2</sup> ]	2,5

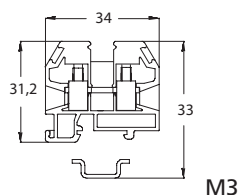

**Mini line-up terminal VS 4 PAM**

dimensions	
thickness of terminal [mm]	6
av. tolerance of engaging on terminals rail [mm]	+0,2
stripping length of conductor [mm]	8
cross-section of conductors	
cross-section of single wire [mm <sup>2</sup> ]	0,3-6,0
cross-section of fine wire [mm <sup>2</sup> ]	0,3-4,0
nominal value (IEC 947-1)	
nominal voltage [V]	440
nominal current [A]	32
nominal cross-section [mm <sup>2</sup> ]	4,0

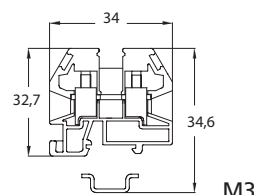

**Ground terminal VS 4 PEM**

dimensions	
thickness of terminal [mm]	7,2
av. tolerance of engaging on terminals rail [mm]	+0,2
stripping length of conductor [mm]	8
cross-section of conductors	
cross-section of single wire [mm <sup>2</sup> ]	0,3-4,0
cross-section of fine wire [mm <sup>2</sup> ]	0,3-4,0
nominal value (IEC 947-1)	
nominal current [A]	34
nominal cross-section [mm <sup>2</sup> ]	4

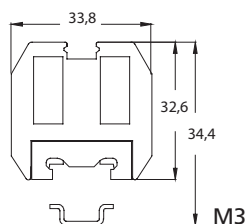

**Ground terminal block VS 4 PE**

dimensions	
thickness of terminal [mm]	7,5
av. tolerance of engaging on terminals rail [mm]	+0,2
stripping length of conductor [mm]	7
cross-section of conductors	
cross-section of single wire [mm <sup>2</sup> ]	1,5-6,0
cross-section of fine wire [mm <sup>2</sup> ]	0,5-4,0
nominal value (IEC 947-1)	
nominal current [A]	35
nominal cross-section [mm <sup>2</sup> ]	4

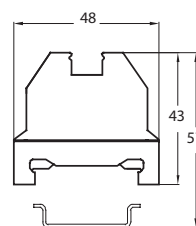

M3

## Technical data - SPOJ

### Ground terminal block VS 6 PE

dimensions	
thickness of terminal [mm]	9
av. tolerance of engaging on terminals rail [mm]	+0,2
stripping length of conductor [mm]	7
cross-section of conductors	
cross-section of single wire [mm <sup>2</sup> ]	1,5-10,0
cross-section of fine wire [mm <sup>2</sup> ]	2,5-6,0
nominal value (IEC 947-1)	
nominal current [A]	43
nominal cross-section [mm <sup>2</sup> ]	6

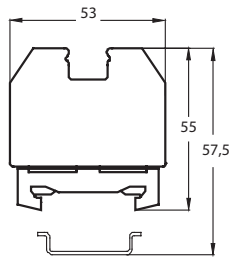

M3

### Ground terminal block VS 16 PE

dimensions	
thickness of terminal [mm]	12
av. tolerance of engaging on terminals rail [mm]	+0,2
stripping length of conductor [mm]	10
cross-section of conductors	
cross-section of single wire [mm <sup>2</sup> ]	4-16
cross-section of fine wire [mm <sup>2</sup> ]	6-16
cross-section of fine wire [mm <sup>2</sup> ]	10-25
nominal value (IEC 947-1)	
nominal current [A]	70
nominal cross-section [mm <sup>2</sup> ]	16

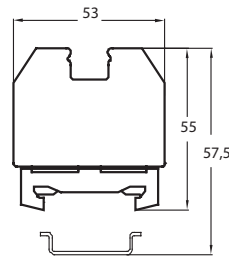

M4

### Ground terminal blok VS 35 PE

dimensions	
thickness of terminal [mm]	16
av. tolerance of engaging on terminals rail [mm]	+0,2
stripping length of conductor [mm]	15
cross-section of conductors	
cross-section of single wire [mm <sup>2</sup> ]	6-35
cross-section of fine wire [mm <sup>2</sup> ]	10-35
cross-section of fine wire [mm <sup>2</sup> ]	10-50
nominal value (IEC 947-1)	
nominal current [A]	95
nominal cross-section [mm <sup>2</sup> ]	35

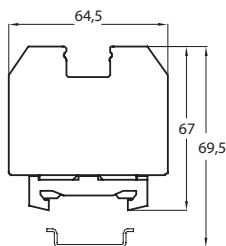

M6

### High current line-up terminal VSU 70

dimensions	
thickness of terminal [mm]	42
av. tolerance of engaging on terminals rail [mm]	+0,3
cross-section of conductors	
cross-section of conduction rail	25x3
nominal value (IEC 947-1)	
nominal voltage [V]	1000
nominal current [A]	192
nominal cross-section [mm <sup>2</sup> ]	70

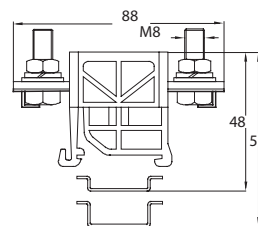

M8

High current line-up terminal VSU 95	
dimensions	
thickness of terminal [mm]	42
av. tolerance of engaging on terminals rail [mm]	+0,3
cross-section of conductors	
cross-section of conduction rail	25x4
nominal value (IEC 947-1)	
nominal voltage [V]	1000
nominal current [A]	232
nominal cross-section [mm <sup>2</sup> ]	95

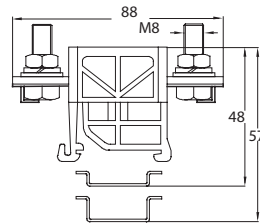

M8

High current line-up terminal VSU 120	
dimensions	
thickness of terminal [mm]	42
av. tolerance of engaging on terminals rail [mm]	+0,3
cross-section of conductors	
cross-section of conduction rail	25x5
nominal value (IEC 947-1)	
nominal voltage [V]	1000
nominal current [A]	269
nominal cross-section [mm <sup>2</sup> ]	120

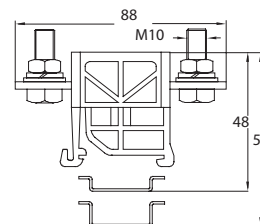

M10

High current line-up terminal VSU 185	
dimensions	
thickness of terminal [mm]	42
av. tolerance of engaging on terminals rail [mm]	+0,3
cross-section of conductors	
cross-section of conduction rail	25x8
nominal value (IEC 947-1)	
nominal voltage [V]	1000
nominal current [A]	353
nominal cross-section [mm <sup>2</sup> ]	185

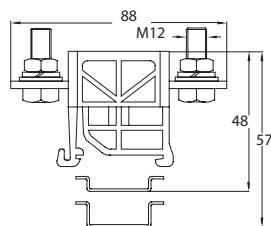

M12

High current line-up terminal VSU 240	
dimensions	
thickness of terminal [mm]	42
av. tolerance of engaging on terminals rail [mm]	+0,3
cross-section of conductors	
cross-section of conduction rail	25x10
nominal value (IEC 947-1)	
nominal voltage [V]	1000
nominal current [A]	415
nominal cross-section [mm <sup>2</sup> ]	240

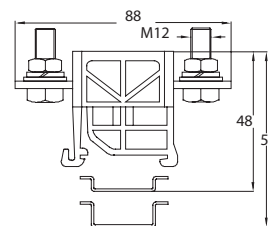

M12

## Protective cover ZP 200

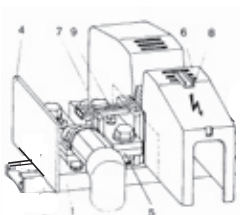

It maintains air gaps and creeping distances among cable lugs of conductors and protects the terminals against electric-shock hazard. It could be mounted on terminals VSU 70 to 150 connected with bridges, though in this case part of protective cover side wall should be cut along the line designed in the inferior. Cover, with the width identical to the width of terminals (42 mm) could be removed by means of screw driver. With terminals VSU 185 and 240 despite the bridging exclusively the usage of end plates KP VSU is required.

## Installation channels IKPS

